

Driver Manual

FS-8700-114 DeviceNet Master Adapter

APPLICABILITY & EFFECTIVITY

Effective for all systems manufactured after February 2021.



Driver Revision: 1.02
Document Revision: 6.A



fieldserver

MSA Safety
1991 Tarob Court
Milpitas, CA 95035
Website: www.MSAsafety.com

U.S. Support Information:
+1 408 964-4443
+1 800 727-4377
Email: smc-support@msasafety.com

EMEA Support Information:
+31 33 808 0590
Email: smc-support.emea@msasafety.com

Contents

1	Description	4
2	Driver Scope of Supply	4
	2.1 Supplied by MSA Safety.....	4
	2.2 Provided by the Supplier of 3 rd Party Equipment	4
	2.2.1 Required 3 rd Party Software.....	4
	2.2.2 Required 3 rd Party Configuration.....	4
	2.2.3 Optional Items	4
3	Hardware Connections	5
	3.1 Hardware Connection Tips / Hints.....	5
4	Data Array Parameters	6
5	DeviceNet Master Configuration	7
	5.1 DeviceNet Settings	7
	5.2 Server Side Connection Parameters	8
	5.3 Server Side Node Parameters.....	8
	5.4 Server Side Map Descriptor Parameters.....	9
	5.4.1 FieldServer Specific Map Descriptor Parameters	9
	5.4.2 Driver Related Map Descriptor Parameters	9
	5.4.3 Map Descriptor Example.....	9
6	Useful Features	10
	6.1 FieldServer LED Indicators.....	10
	6.2 Configure as a DeviceNet Secondary Master with Shared Inputs	11
7	Troubleshooting	13
8	Reference	13
	8.1 Set DeviceNet MAC ID and Baudrate	13
	8.2 Use Command and Status Data Arrays	14
	8.3 Master Status Codes	14
	8.4 Understanding Buffer Types and Map Descriptor Functions	15
	8.5 Accessing	15

1 Description

The DeviceNet Master Adapter driver can be used to emulate a single Master Scanner station on a DeviceNet network. The FieldServer DeviceNet adapter is implemented as an ODVA profile 12 communications adapter. Standard DeviceNet baud rates of 125k, 250k and 500kbit/s are supported. The DeviceNet Master Scanner can open IO connections of up to a total of 1536 Bytes in each direction to DeviceNet Slaves.

Max Nodes Supported

FieldServer Mode	Nodes	Comments
Client	1	The FieldServer can only emulate one DeviceNet Master station.
Server	63	The driver can communicate with up to 63 Slaves if the FieldServer point count license is not exceeded.

2 Driver Scope of Supply

2.1 Supplied by MSA Safety

Part #	Description
DeviceNet-Master	Anybus-M DeviceNet Card

2.2 Provided by the Supplier of 3rd Party Equipment

2.2.1 Required 3rd Party Software

RSNetWorx, RSLogix or another Network Scheduling Tool.

2.2.2 Required 3rd Party Configuration

Connection to a properly terminated DeviceNet network.

2.2.3 Optional Items

Part #	Vendor/Manufacturer	Description
-	HMS-Networks	Anybus-M DeviceNet EDS file

3 Hardware Connections

The FieldServer is connected to the DeviceNet network as shown in the connection drawing below.

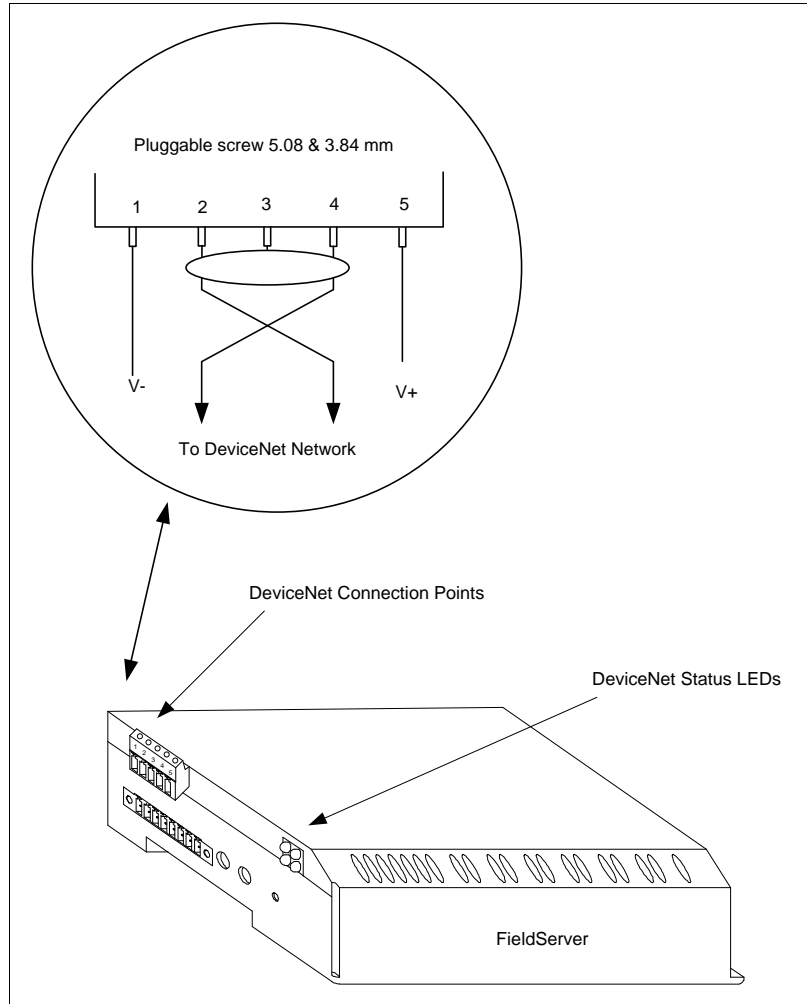

Connector Pinouts

Pin	Signal	Description	Wire color
1	V-	Negative supply voltage	black
2	CAN_L	CAN_L Bus line	blue
3	SHIELD	Cable Shield	(bare)
4	CAN_H	CAN_H Bus line	white
5	V+	Positive Supply Voltage	red

3.1 Hardware Connection Tips / Hints

- Use the recommended network cable and terminators as specified by the DeviceNet network organization and/or the manufacturer of your network equipment.
- Terminate each end of the DeviceNet network with a 121 Ω resistor.
- The bus interface shall be supplied with 24DC \pm 10% on the Fieldbus connector.
- The DeviceNet Master Card's network current consumption is maximum 50mA = 0.05 Amps.

4 Data Array Parameters

Data Arrays are “protocol neutral” data buffers for storage of data to be passed between protocols. It is necessary to declare the data format of each of the Data Arrays to facilitate correct storage of the relevant data.

Section Title		
Data_Arrays		
Column Title	Function	Legal Values
Data_Array_Name	Provide name for Data Array.	Up to 15 alphanumeric characters
Data_Array_Format	Provide data format. Each Data Array can only take on one format.	Float, Bit, Byte, Uint16, Uint32, Sint16, Sint32
Data_Array_Length	Number of Data Objects. Must be larger than the data storage area required by the Map Descriptors for the data being placed in this array.	1-10000

Example

```
// Data Arrays
Data_Arrays
Data_Array_Name , Data_Array_Format , Data_Array_Length
DA_AI_01 , Uint16 , 200
DA_AO_01 , Uint16 , 200
DA_DI_01 , Bit , 200
```

5 DeviceNet Master Configuration

For detailed information on FieldServer configuration, refer to the FieldServer Configuration Manual. The information that follows describes how to expand upon the factory defaults provided in the configuration files included with the FieldServer (see “.csv” files provided with the FieldServer).

This section documents and describes the parameters necessary for configuring the FieldServer to communicate with a DeviceNet Slave.

The configuration file tells the FieldServer about its interfaces, and the routing of data required. In order to enable the FieldServer for DeviceNet communications, the driver independent FieldServer buffers need to be declared in the “Data Arrays” section, the FieldServer virtual node(s) needs to be declared in the “Server Side Nodes” section, and the data to be provided to the Clients’ needs to be mapped in the “Server Side Map Descriptors” section. Details on how to do this can be found below.

NOTE: In the tables below, * indicates an optional parameter, with the bold legal value as default.

5.1 DeviceNet Settings

Section Title		
FieldServer		
Column Title	Function	Legal Values
System_Station_Address*	DeviceNet MAC ID of the FieldServer	0-63

NOTE: The DeviceNet MAC ID can also be set via the DIP switches on the side of the FieldServer but then the system station address parameter must be removed from the configuration file. Refer to Section 8.1 for more information.

Example

```
// FieldServer  
  
FieldServer  
Title           , System_Station_Address  
DeviceNet_Test, , 5
```

5.2 Server Side Connection Parameters

Section Title		
Connections		
Column Title	Function	Legal Values
Adapter	Adapter Name	DNet
Protocol	Protocol name	X30_DNet_Master
DNet_Master_Baudrate1	Baud rate	125K, 250K, 500K
Command_DA_Name	Commanding Scanner	Name of a data array declared under Section 4 , length of 8 - Bit data array type recommended.
Status_DA_Name	Provide Scanner status	

Example

```
// Server Side Connections

Connections
Adapter , Protocol , DNet_Master_Baudrate , Command_DA_Name , Status_DA_Name
DNet , X30_DNet_Master , 500K , Command_Reg , Status_Reg
```

5.3 Server Side Node Parameters

Section Title		
Nodes		
Column Title	Function	Legal Values
Node_Name	Provide name for node.	Up to 32 alphanumeric characters
Node_ID	MAC ID of Slave to scan.	0 - 63
Protocol	Specify protocol used.	X30_DNet_Master

Example

```
// Server Side Nodes

Nodes
Node_Name , Node_ID , Protocol
DN1 , 01 , X30_DNet_Master
```

¹ If System_Station_Address has not been defined in the CSV file, the DIP switch value for both MacID and Baudrate will be used and the baud parameter in the CSV file will be ignored.

5.4 Server Side Map Descriptor Parameters

5.4.1 FieldServer Specific Map Descriptor Parameters

Column Title	Function	Legal Values
Map_Descriptor_Name	Name of this Map Descriptor.	Up to 32 alphanumeric characters
Data_Array_Name	Name of Data Array where data is to be stored in the FieldServer.	One of the Data Array names from Section 4
Data_Array_Offset	Starting location in Data Array.	0 to maximum as specified in Section 4
Function	Function of Server Map Descriptor.	RDBC - Reads data from the remote input buffer WRBC - Writes data to the remote output buffer
Scan_Interval	Buffers Update Period.	> 0.001s

5.4.2 Driver Related Map Descriptor Parameters

Column Title	Function	Legal Values
Node_Name	Name of Node or panel for which this Map Descriptor holds points.	One of the Node names specified in Section 5.3
DeviceNet_Data_Type	Data Type of remote buffer.	Byte, Word, Dword, Float, Bool
Address	Byte offset into remote buffer.	RDBC: 0 – 1535 WRBC: 0 – 1535
Length	Number of DeviceNet_Data_Type items in remote buffer.	BYTE: 1 – 1536 WORD: 1 – 768 DWORD: 1 – 384 FLOAT: 1 – 384 BOOL: 1 – 12288

5.4.3 Map Descriptor Example

```
// Server Side Map Descriptors

Map_Descriptors
Map_Descriptor_Name , Data_Array_Name , Data_Array_Offset , Function , Node_Name
Get_Data , Input_Data , 0 , RDBC , CN1
Put_Data , Output_Data , 0. , WRBC , CN1

, DeviceNet_Data_Type , Address , Length , Scan_Interval
, WORD , 0 , 10 , 1s
, WORD , 0 , 10 , 1s
```

Example comments:

- Function – Read function map descriptor gets data from the DeviceNet network and stores it in the Input_Data data array. Write function map descriptor puts data from the Output_Data data array onto the DeviceNet network.
- Address & Length – Each address refers to an individual remote input and output buffer. Each buffer can contain up to 1536 bytes.

6 Useful Features

6.1 FieldServer LED Indicators

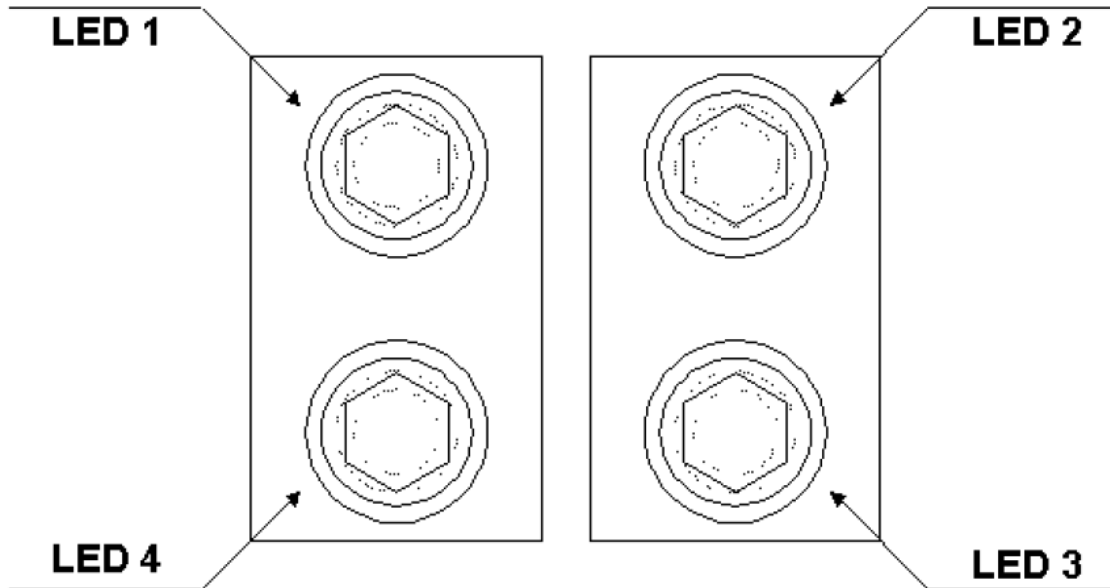

LED 1 – Reserved

LED 2 – Network Status

Color	Frequency	Description
-	Off	No power, not initialized or no connections established
Green	On	Online, one or more connections established
Green	Flashing	Online, no connections established
Red	On	Critical link failure
Red	Flashing	Minor fault, one or more connections have a minor fault

LED 3 – Module Status

Color	Frequency	Description
-	Off	No power or not initialized
Green	On	Module status is OK
Red	On	Major fault
Red	Flashing	Minor fault

LED 4 – Operation Mode

Color	Frequency	Description
-	Off	No power or not initialized
Green	Flashing	Idle mode
Green	On	Run mode

6.2 Configure as a DeviceNet Secondary Master with Shared Inputs

Shared inputs are a function of a scanner (Master) that allows it to listen to devices that are in another scanner's scanlist. When the shared inputs function is enabled, the scanner will not open a Master/Slave connection with that device. It merely listens for the inputs from that device over the predefined Master/Slave Connection Set. Note that a slave device still can only have one master.

A Sample network configuration using the HMS Anybus NetTool for DeviceNet is shown below. In this example the FieldServer's MAC ID is 6 and it is setup as a Secondary Master or Passive Scanner. The DeviceNet network's name or Active Scanner is implemented by the device with MAC ID 7.

NOTE: A Secondary Master Device is not allowed to produce outputs on the DeviceNet Network, and therefore only RDBC Map Descriptors may be used in the FieldServer's configuration file. See the RDBC Map Descriptor in Section 5.4.3.

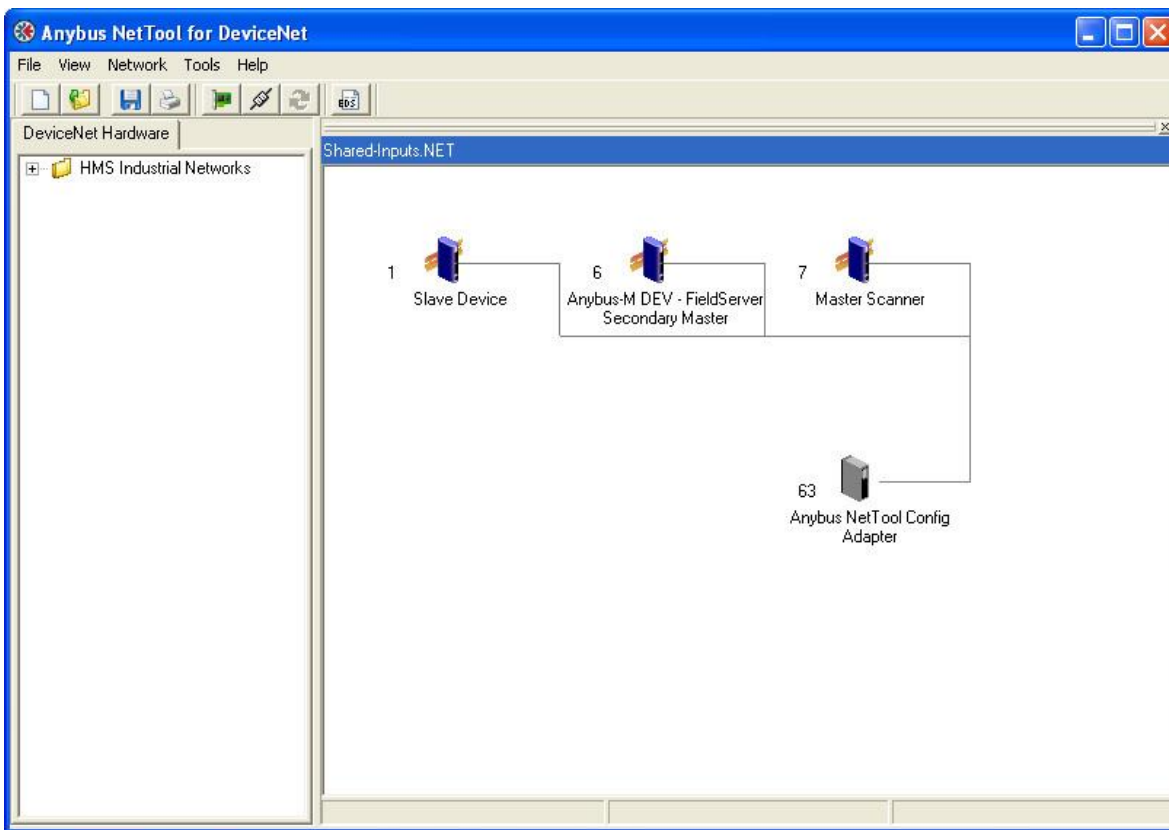

Additional Information

To enable the use of shared inputs, select the Slave Device at MAC ID 1 and the FieldServer Device at MAC ID 6, and add both to the FieldServer's scan list as shown below.

NOTE: The red arrow  indicating the use of shared inputs will only show up if the FieldServer DeviceNet card and Electronic Data Sheet (EDS file) supports this function. Insure using the latest EDS file.

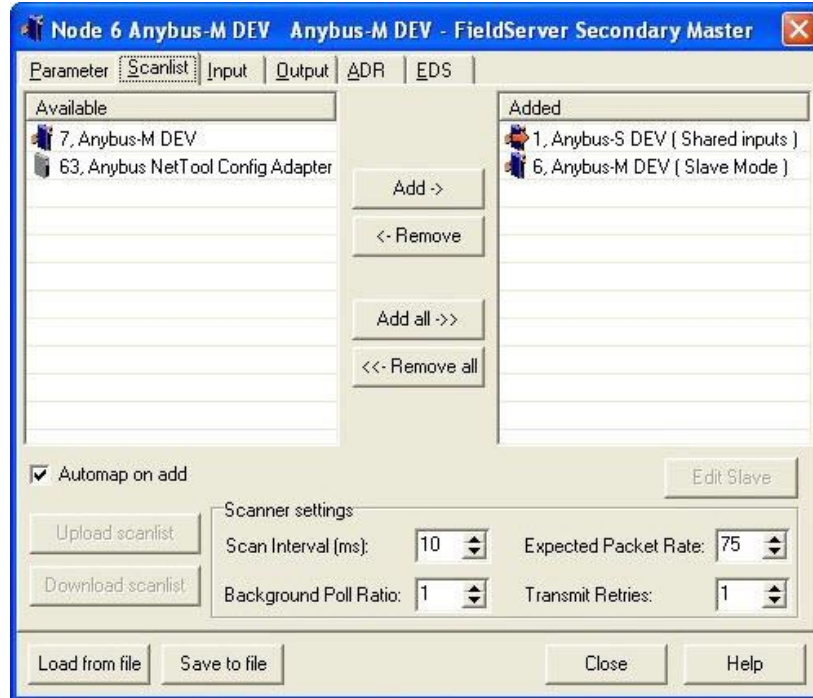

The Main Network Scanner is configured normally by just scanning Slave Devices as shown below.

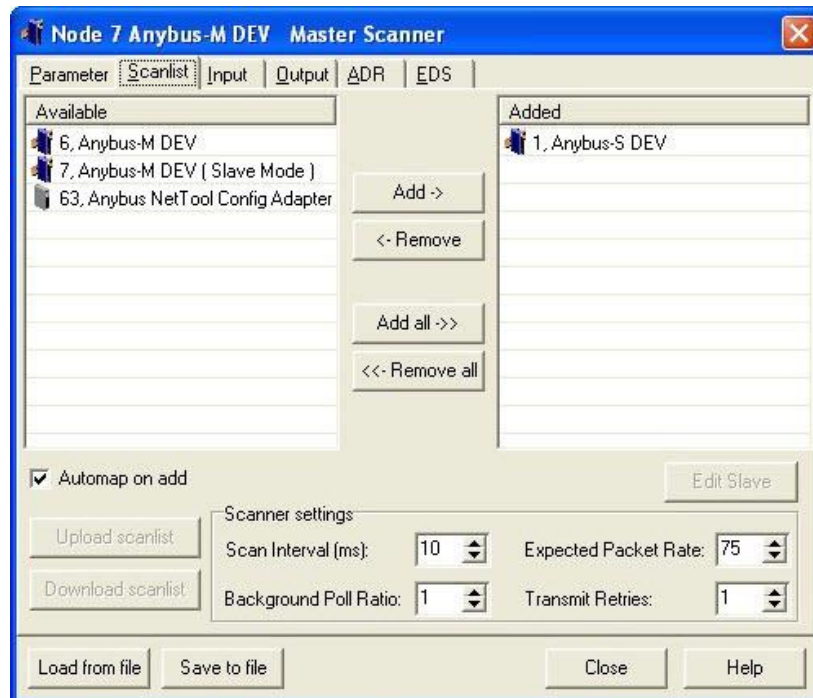

7 Troubleshooting

If there is no 24V DC supply on the DeviceNet Network or if the power supply current is not enough to support the entire network, then the FieldServer will report that any device configured in the config file is not in the master scan list, regardless if it is in the scan list or not.

8 Reference

8.1 Set DeviceNet MAC ID and Baudrate

The MAC ID and Baudrate can be set in the FieldServer's CSV file using the System_Station_Address and DNet_Master_Baudrate parameters or it can be set with DIP switches as depicted below.

NOTE: The System_Station_Address parameter must be removed from the configuration file if the DIP switch setting is to be used. If System_Station_Address has not been defined in the CSV file, the DIP switch value for both MacID and baud rate will be used and the baud parameter in the CSV file will be ignored.

(ON = "1", OFF = "0")

Baudrate [kBit/sec]	DIP 1-2
125	00
250	01
500	10
Reserved	11

Address	DIP 3 - 8
0	000000
1	000001
2	000010
3	000011
...	
62	111110
63	111111

8.2 Use Command and Status Data Arrays

The Command Data Array controls the Scanner's mode which can be either Run or Idle. The Scanner can only be configured when in Idle mode. A non-zero value at offset zero in the Command Data Array will place the Scanner in Run mode; a value of zero will place it in Idle mode. The Scanner always powers up in Idle mode and can be set to Run mode automatically with a preload section or from the Server side protocol of the FieldServer. The following preload section can be placed in the configuration file to place the scanner in Run mode at power-up:

```
Preloads
Data_Array_Name , Preload_Data_Format , Preload_Data_Value , Location
Command_Reg , Bit , 1 , 0
```

Offset zero of the Status Data Array indicates the Scanner's actual mode achieved. A non-zero value indicates the Scanner is in Run mode and a value of zero indicates the scanner is in Idle mode.

8.3 Master Status Codes

The Master Status codes displayed on the F-screen are depicted below.

Value Dec	Value Hex	Meaning
00	0x00	OK or Not in scan list
70	0x46	Duplicate MAC ID failure
71	0x47	Scanner configuration error
72	0x48	Device communication error
73	0x49	Wrong device type
74	0x4A	Port over-run error
75	0x4B	Network failure
76	0x4C	No CAN messages detected
77	0x4D	Wrong data size
78	0x4E	No such device found
79	0x4F	Transmit failure
80	0x50	Node in IDLE mode
81	0x51	Node in fault mode
82	0x52	Fragmentation error
83	0x53	Unable to initialize node

Value Dec	Value Hex	Meaning
84	0x54	Node not yet initialized
85	0x55	Receive buffer overflow
86	0x56	Node changed to IDLE mode
87	0x57	Shared master error (not used)
88	0x58	Shared choice error (not used)
89	0x59	Keeper object failure (not used)
90	0x5A	CAN port disabled (not used)
91	0x5B	Bus off
92	0x5C	No bus power detected
95	0x5F	Updating flash (not used)
96	0x60	In test mode (not used)
97	0x61	Halted by user cmd. (not used)
98	0x62	Firmware failure (not used)
99	0x63	System failure

Example:

In the FS-GUI, under the User Messages driver tab, the following type of message will be displayed when the master reports a network failure:

```
Master node 6 Status code = 76
Remote device 2 is not configured in master scan list!
Master node 6 Status code = 76
Remote device 1 is not configured in master scan list!
...
```

8.4 Understanding Buffer Types and Map Descriptor Functions

The diagram below explains the data flows for both buffers when using the FieldServer as a DN Master:

Note that for the Input buffer, the data is coming from the external DN Slave and is transferred into the DN Master card's internal input buffer. The RDBC (Read Data Block Continuous) Map Descriptor transfers the data from the card buffer into the FieldServer's Data Array packing it as specified in DeviceNet_Data_Type.

For the Output buffer, the data is written from the FieldServer's Data Array by the WRBC function Map Descriptor (Write Data Block Continuous) into the DN Master card's internal output buffer from where it is transferred across the DeviceNet network to the external DN Slave's input buffer.

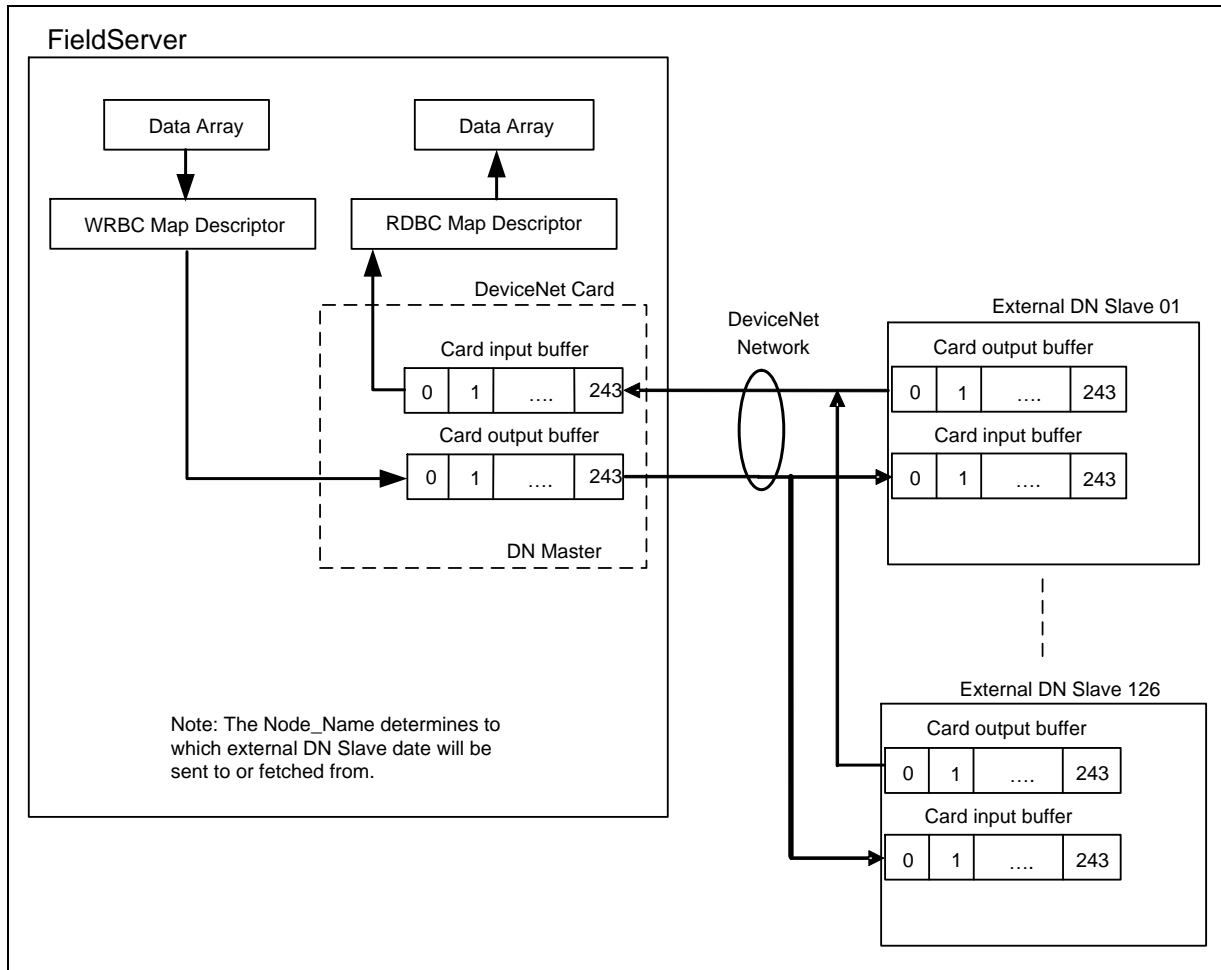

8.5 Accessing

The DeviceNet driver only supports IO data. To access parameter data on Slaves it is necessary to refer to the Slave device's user manuals for information on how to map their parameter data to IO data.